

**SINGER**  
**61W77**

# LIST OF PARTS

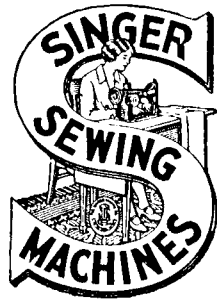

## MACHINE No. 61w77

THE SINGER MANUFACTURING COMPANY

## INDEX

|                               | PAGE |
|-------------------------------|------|
| ACCESSORIES .....             | 13   |
| BORBIN WINDER .....           | 16   |
| KNEE LIFTER .....             | 17   |
| MACHINE No. 61w77 .....       | 7    |
| MISCELLANEOUS PARTS .....     | 18   |
| NUMERICAL LIST OF PARTS ..... | 19   |
| THREAD UNWINDER .....         | 18   |

From the library of: Diamond Needle Corp

# Instructions for Ordering

In ordering from this list, use **ONLY** the **PART** number in the **FIRST** column.

The number stamped on a Sewing Machine Part is the number of the Single Part only, except when the part includes Set Screws, Clamping Screws, Studs and Rollers Spun on, Small Wires riveted, or Parts soldered together, etc., which it is necessary to furnish in combination.

Every combination of parts sent out has its specific number which, although **not** stamped on Parts (except in above case), must be used when ordering the combination.

Each number always indicates the **SAME PART** in whatever list it appears, or for whatever Machine.

The letters after some of the numbers indicate the style of finish only, as follows:

- A. Hardened, Polished and Plated.
- B. Polished and Plated.
- C. Hardened only.
- D. Polished only.
- E. Soft, not polished.
- F. Hardened and Polished.
- H. Blued.
- J. Nickel Plated only
- R. Merlized.
- Y. Black Nickel Plated only.

These letters **MUST BE USED** when they appear in the list and **AFTER** the number, as in the list.

In this series

- 200001 to 201500 and 350001 to 351500 are Screw Numbers.
- 201501 to 201800 and 351501 to 351800 are Nut Numbers.
- 201801 to 202000 and 350801 to 352000 are Roller Numbers.
- 202001 to 350000 are Numbers of Machine Parts.

The figures in the second column refer only to the plate in which the illustration of the part is shown and are **NOT TO BE USED** in ordering.

Two or more numbers over a cut indicate that the difference between such parts is not visible in an illustration.

Parts marked with an asterisk (\*) are furnished only when repairs are made at the factory.

## LIST OF PARTS COMPLETE

FOR

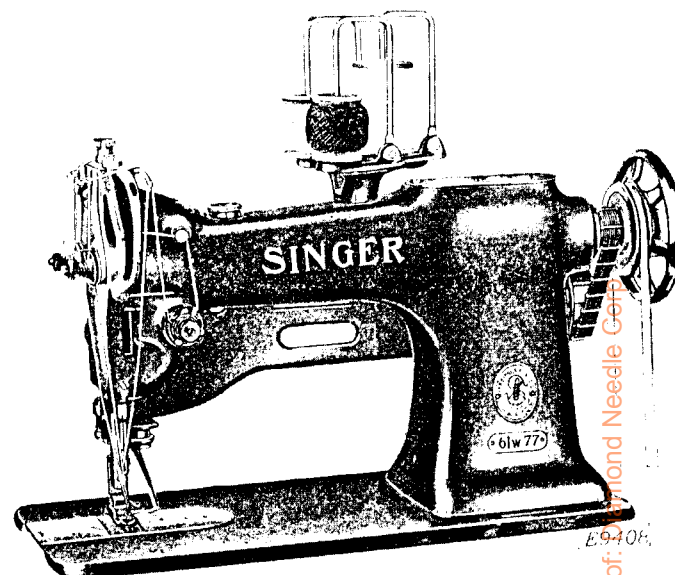

### MACHINE No. 61w77

For Embroidery Work

Weaves a cord or cords into the stitches for an embroidery effect

| No.     | Plate | Name  |
|---------|-------|---|
| *207090 | —     | Arm .....   |
| *244042 | —     | Bracket .....   |
| 202562  | 10285 | “ “ Brace with 200057F ....                           |
| 200057F | 10285 | “ “ “ Pinch Screw ....                                |
| 200330c | 13396 | “ “ “ Screw .....                                     |
| 201528E | 13396 | “ “ “ “ Nut .....                                     |
| 200558H | 10285 | “ “ Screw (lower) .....                               |
| 350168H | 13396 | “ “ “ (long, upper) ....                              |
| 200769E | 13396 | “ “ “ (short, upper) ...                              |
| 201522E | 10246 | “ “ “ Nut (2) .....                                   |
| 225532  | 10285 | “ “ “ Washer (2) .....                                |
| 202563  | 13372 | “ “ Shaft .....                                       |
| 202564  | 13396 | “ “ “ Bevel Gear, 24<br>teeth, with two 200395c ..... |
| 200395c | 13396 | Arm Bracket Shaft Bevel Gear Set<br>Screw .....       |

From the library of: Grand Needle Co.

## Parts for Machine No. 61w77

| No.     | Plate | Name   |
|---------|-------|--|
| 261508  | 13396 | Arm Bracket Shaft Collar with two 201052c .....            |
| 201052c | 13396 | Arm Bracket Shaft Collar Set Screw                         |
| *202569 | ----- | " " " " Driving Pulley                                     |
| 200363c | 10248 | " " " " " " Set Screw .....                                |
| 202565  | 10285 | Arm Bracket Shaft Pulley with 202253 and two 200394c ..... |
| 202566  | 13372 | Arm Bracket Shaft Pulley Belt                              |
| 200394c | 13396 | " " " " " " Set Screw .....                                |
| 202253  | 10244 | Arm Bracket Shaft Pulley Spring Flange .....               |
| 202247  | 13372 | Arm Cap .....  |
| 200278H | 10244 | " " Screw .....  |
| 202248  | 10244 | " " " Washer .....   |
| 204235  | 13392 | " Position Pin (2) .....                                   |
| 200010E | 10245 | " Screw (3) .....  |
| 202005  | 10245 | " " Washer (3) .....                                       |
| 202567  | 13372 | " Shaft with 200367E and 224392                            |
| 203159  | 13372 | " " Bushing (back) with 202244 .....                       |
| 202244  | ----- | Arm Shaft Bushing (back) Oil Packing (wick) .....          |
| 200338c | 10244 | Arm Shaft Bushing (back) Set Screw .....                   |
| 207080  | 13372 | Arm Shaft Bushing (front) with 202244 .....                |
| 202244  | ----- | Arm Shaft Bushing (front) Oil Packing (wick) .....         |
| 200502B | 10246 | Arm Shaft Bushing (front) Oil Packing Thumb Screw .....    |
| 200338c | 10244 | Arm Shaft Bushing (front) Set Screw .....                  |
| 202530  | 13372 | Arm Shaft Connection Belt .....                            |
| 202252  | 10244 | " " " " Pulley with 200327c, 200602E and two 202253 .....  |
| 200602E | 10244 | Arm Shaft Connection Belt Pulley Position Screw .....      |
| 200327c | 10244 | Arm Shaft Connection Belt Pulley Set Screw .....           |
| 202253  | 10244 | Arm Shaft Connection Belt Pulley Spring Flange .....       |
| 224392  | ----- | Arm Shaft Oil Packing (wick) .....                         |
| 200367E | 13396 | " " " " Stop Screw (left hand) .....                       |

## Parts for Machine No. 61w77

| No.     | Plate | Name   |
|---------|-------|--|
| *202568 | ----- | Balance Wheel (belt groove 2 1/2 in. diam.) .....  |
| 202962  | 13374 | Balance Wheel complete, Nos. 202568, 202569 and two 200363c ..                                       |
| *207081 | ----- | Bed .....  |
| 207082  | 13397 | " Plate (back) .....   |
| 200577H | 10245 | " " " Screw .....  |
| 207083  | 13397 | " Slide (front) .....  |
| 202265  | 13392 | Bobbin .....   |
| *202806 | ----- | " Case .....   |
| 202267  | 13392 | " " Latch .....  |
| *202056 | ----- | " " " Pin .....  |
| 202269  | 13392 | " " " Plunger .....  |
| 202270  | 13392 | " " " Spring .....   |
| 202716  | 13392 | " " Tension Spring .....   |
| 200984c | 13392 | " " " " " " Regulat- ing Screw .....   |
| 200594c | 13392 | Bobbin Case Tension Spring Screw   |
| 202533  | 13396 | Bobbin Case complete, Nos. 200594c, 200984c, 202056, 202267, 202269, 202270, 202716 and 202806 ..... |
| 236097  | 13396 | Cord Guide .....   |
| 200174H | 13396 | " " Screw .....  |
| 202572  | 13396 | " " Pin .....  |
| 244043  | 13396 | " Guiding Arm .....  |
| 244044  | 13396 | " " " Bracket with 200061c .....   |
| 200061c | 13396 | Cord Guiding Arm Bracket Pinch Screw .....   |
| 350296c | 13396 | Cord Guiding Arm Hinge Screw .....   |
| 201516E | 10285 | " " " " " " Nut  |
| 244045  | 13397 | " " Eccentric Shaft .....  |
| 202564  | 13396 | " " " " Bevel Gear, 24 teeth, with two 200395c   |
| 202575  | 13397 | Cord Guiding Eccentric Shaft Bevel Gear Guard .....  |
| 200564c | 13396 | Cord Guiding Eccentric Shaft Bevel Gear Guard Screw .....  |
| 200395c | 13396 | Cord Guiding Eccentric Shaft Bevel Gear Set Screw .....  |
| 213639  | 13396 | Cord Guiding Eccentric Shaft Collar with 200380c .....   |
| 200380c | 13396 | Cord Guiding Eccentric Shaft Collar Set Screw .....  |
| 202577  | 13397 | Cord Tension Bracket .....   |
| 200164D | 13396 | " " " Screw .....  |
| 244048  | 10247 | " " Disc .....   |
| 202572  | 13396 | " " " Stop Pin .....   |
| 202579  | 13399 | " " Spring .....   |

From the library of Diamond Medical Corp.

## Parts for Machine No. 61w77

| No.     | Plate | Name   |
|---------|-------|--|
| 202580  | 13399 | Cord Tension Spring Washer .....   |
| 200618R | 13399 | " " Stud .....   |
| 201572R | 10881 | " " " Thumb Nut .....  |
| 202960  | —     | Cord Tension Bracket complete,<br>Nos. 202577, two each 200164R,<br>200174R, 200618R, 201572R, 202579,<br>202580, 236097, four each 202572<br>and 244048 ..... |
| 202581  | —     | Face Plate .....   |
| 202961  | 13374 | Face Plate complete, Nos. 202581<br>and 202960 .....   |
| 202135  | 10245 | Face Plate Position Pin .....  |
| 200462R | 10245 | " " Thumb Screw .....  |
| 202275  | 13398 | Feed Bar .....   |
| 200641C | 10246 | " " Hinge Screw (driving)..  |
| 201522E | 10246 | " " " " Nut .....  |
| 202276  | 10245 | " " Slide Block .....  |
| 202298  | 10245 | " " " " Crank with<br>200038C .....  |
| 203124  | —     | Feed Bar Slide Block Crank 202298<br>with 200205E, 201518E and 202276  |
| 200038C | 10245 | Feed Bar Slide Block Crank Pinch<br>Screw .....  |
| 200205E | 10245 | Feed Bar Slide Block Hinge Screw   |
| 201518E | 10245 | " " " " " "  |
|         |       | Nut .....  |
| 202282  | 13399 | Feed Dog, for 202818 .....   |
| 200106E | 10245 | " " Screw (2) .....  |
| 202297  | 13374 | " Driving Connection with 200054E<br>and 202277 .....  |
| 202298  | 10245 | Feed Driving Connection Crank<br>with 200038C .....  |
| 200038C | 10245 | Feed Driving Connection Crank<br>Pinch Screw .....   |
| 200545C | 10245 | Feed Driving Connection Hinge<br>Screw .....   |
| 201518E | 10245 | Feed Driving Connection Hinge<br>Screw Nut .....   |
| 202277  | —     | Feed Driving Connection Oil Pack-<br>ing (wick) .....  |
| 200054E | 10246 | Feed Driving Connection Pinch<br>Screw .....   |
| 202300  | 10246 | Feed Driving Eccentric Regulating<br>Bracket .....   |
| 203134  | —     | Feed Driving Eccentric Regulating<br>Bracket 202300 with 202252, two<br>each 201014C and 201525E .....   |
| 201014C | 10245 | Feed Driving Eccentric Regulating<br>Bracket Hinge Screw .....   |

## Parts for Machine No. 61w77

| No.     | Plate | Name  |
|---------|-------|---|
| 201525E | 10245 | Feed Driving Eccentric Regulating<br>Bracket Hinge Screw Nut .....              |
| 202301  | 10246 | Feed Driving Eccentric Regulating<br>Bracket Plunger .....                      |
| 202595  | 10246 | Feed Driving Eccentric Regulating<br>Bracket Plunger Spring .....               |
| 200607C | 10246 | Feed Driving Eccentric Regulating<br>Bracket Plunger Spring Stop<br>Screw ..... |
| 201014C | 10245 | Feed Driving Eccentric Regulating<br>Bracket Stop Screw .....                   |
| 201525E | 10245 | Feed Driving Eccentric Regulating<br>Bracket Stop Screw Nut .....               |
| 200429C | 10246 | Feed Driving Eccentric Regulating<br>Screw .....                                |
| 200383C | 10246 | Feed Driving Eccentric Regulating<br>Screw Check Screw .....                    |
| 202303  | 13374 | Feed Driving Rock Shaft .....   |
| 206860  | —     | " " " " 202303 with<br>200641C, 201522E and 202275 .....                        |
| 202305  | 10245 | Feed Driving Rock Shaft Center (2)  |
| 200043C | 10246 | " " " " " " Set<br>Screw (2) .....  |
| 202306  | 13374 | Feed Lifting Connection with<br>200054E and 202277 .....                        |
| 202307  | 10246 | Feed Lifting Connection Eccentric<br>with 200382C and 200437C .....             |
| 200437C | 10246 | Feed Lifting Connection Eccentric<br>Position Screw .....                       |
| 200382C | 13399 | Feed Lifting Connection Eccentric<br>Set Screw .....                            |
| 200545C | 10245 | Feed Lifting Connection Hinge<br>Screw .....                                    |
| 201518E | 10245 | Feed Lifting Connection Hinge<br>Screw Nut .....                                |
| 202277  | —     | Feed Lifting Connection Oil Pack-<br>ing (wick) .....                           |
| 200054E | 10246 | Feed Lifting Connection Pinch<br>Screw .....                                    |
| 202308  | 13374 | Feed Lifting Rock Shaft .....   |
| 202305  | 10245 | " " " " Center (2)  |
| 200043C | 10246 | " " " " " " Set<br>Screw (2) .....  |
| 202582  | 13397 | Feed Regulating Spindle with 202583<br>and 202619 .....                         |
| *202583 | —     | Feed Regulating Spindle Head ....   |
| 202619  | 13392 | " " " " Posi-<br>tion Pin .....   |

From the library of: Diamond Needs Corp.

## Parts for Machine No. 61w77

| No.     | Plate | Name   |
|---------|-------|--|
| *244010 | —     | Hook (sewing) .....  |
| 244011  | 13397 | " 244010 with 200145c, 200596F,<br>200614c, 202320, 203101, 206775,<br>206852 and 244014 ..... |
| 244012  | —     | Hook and Bobbin Case complete,<br>Nos. 202533 and 244011 .....                                 |
| 244013  | 13392 | Hook Counter Balance with 200444c  |
| 200444c | 13392 | " " " Position Screw   |
| 206852  | 13392 | " GIB .....  |
| 200614c | 13392 | " " Hinge Screw .....  |
| 200596F | 13392 | " " Screw .....  |
| 203101  | —     | " Oil Wick .....   |
| *202320 | —     | " Shaft, 11 <sup>7</sup> / <sub>16</sub> in. long .....  |
| 202321  | 10245 | " " Bushing (back) .....   |
| 200346c | 10245 | " " " " Set Screw  |
| 202322  | 10245 | " " " (front) .....  |
| 200346c | 10245 | " " " " Set Screw ..   |
| 202323  | 10244 | " " Connection Belt Pulley<br>with 202324 and two 201018c .....                                |
| 201018c | 13392 | Hook Shaft Connection Belt Pulley<br>Set Screw .....   |
| 202324  | 10244 | Hook Shaft Connection Belt Pulley<br>Spring Flange .....                                       |
| 202260  | —     | Hook Shaft Oil Packing (wick) (2)  |
| 206775  | 13392 | " " Pin .....  |
| 244014  | 13392 | " Washer .....   |
| 200145c | 13392 | " " Screw .....  |
| 237837  | 13398 | Knee Lifter Connection Lever .....   |
| 202447  | 13398 | " " " " Lift-<br>ing Rod with 202302 .....   |
| 202302  | 10248 | Knee Lifter Connection Lever Lift-<br>ing Rod Cotter Pin .....                                 |
| 244034  | 13398 | Knee Lifter Lifting Lever .....  |
| 202326  | 10248 | Needle Bar with 200141F .....  |
| 202327  | 10248 | " " Bushing .....  |
| 203123  | —     | " " " 202327 with 202326   |
| 200352c | 10248 | " " " Set Screw .....  |
| 202331  | 10248 | " " Connecting Link .....  |
| 236073  | 13392 | " " " " Oil<br>Guard .....   |
| 200161b | 10247 | Needle Bar Connecting Link Oil<br>Guard Screw .....  |
| 202333  | 10248 | Needle Bar Connecting Link Stud<br>with 202254 .....   |
| 202254  | —     | Needle Bar Connecting Link Stud<br>Oil Packing (wick) .....                                    |
| 200374c | 13399 | Needle Bar Connecting Link Stud<br>Set Screw .....   |

## Parts for Machine No. 61w77

| No.     | Plate | Name   |
|---------|-------|--|
| *206891 | —     | Needle Bar Connecting Stud .....                                       |
| 202329  | 10248 | " " " " 206891<br>with 200086c and 202330 .....                        |
| 202330  | —     | Needle Bar Connecting Stud Oil<br>Packing (wick) .....                 |
| 200086c | 10248 | Needle Bar Connecting Stud Pinch<br>Screw .....                        |
| 202328  | 13398 | Needle Bar Crank with 200335c,<br>200428c, 202333 and two 200374c      |
| 203117  | —     | Needle Bar Crank 202328 with<br>202329, 202331 and 202398 to 202400    |
| 203172  | 10248 | Needle Bar Crank Friction Washer                                       |
| 200428c | 10248 | " " " Position Screw   |
| 200335c | 10244 | " " " Set Screw .....  |
| 200141F | 10248 | " Set Screw .....  |
| 244033  | —     | Presser Bar (hollow) .....   |
| 202335  | 13398 | " " 244033 with 200074F  |
| 207072  | 10249 | " " Pushing .....  |
| 200352c | 10248 | " " " Set Screw ..   |
| 202339  | 10249 | " " Lifter .....   |
| 200653c | 10249 | " " " Hinge Screw ..   |
| 244004  | 10249 | " " Lifting Releasing Lev-<br>er Bracket .....                         |
| 200260b | 10249 | Presser Bar Lifting Releasing Lev-<br>er Bracket Guide Screw .....     |
| 206608  | 10249 | Presser Bar Lifting Releasing Lev-<br>er Bracket Spring (spiral) ..... |
| 202337  | 10249 | Presser Bar Position Guide .....                                       |
| 202338  | 10249 | " " " " Lever<br>with 200086F .....                                    |
| 200086F | 10248 | Presser Bar Position Guide Lever<br>Pinch Screw .....                  |
| 200352c | 10248 | Presser Bar Position Guide Set<br>Screw .....                          |
| 202343  | 13399 | Presser Bar Spring (light) .....                                       |
| 202346  | 10249 | " " " Stop Rod .....   |
| 200492b | 10249 | " " Thumb Screw (pres-<br>sure regulating) .....                       |
| 200475b | 13399 | Presser Bar Thumb Screw Thumb<br>Set Screw .....                       |
| 202355  | 13399 | Presser Bar Thumb Screw Thumb<br>Set Screw Packing (brass) .....       |
| 202090  | 13399 | Presser Foot Hinge Pin .....   |
| 244046  | —     | " " Plate .....  |
| 202923  | —     | " " Shank .....  |
| 200074F | 10249 | " " Screw .....  |
| 244047  | 13399 | Presser Foot (hinged) complete,<br>Nos. 202090, 202923 and 244046 ..   |

## Parts for Machine No. 61w77

| No.     | Plate | Name   |
|---------|-------|--|
| 202068  | 13374 | Spool Holder Base .....  |
| 206541  | 13374 | " " " Bracket .....  |
| 200265E | 13399 | " " " " Screw ...  |
| 206542  | 13374 | Spool Holder Base Bracket complete, Nos. 206541, three each 200575H and 204297 .....     |
| 200575H | 13399 | Spool Holder Base Screw .....  |
| 204296  | 13374 | " " Wire .....   |
| 200079H | 13399 | " " " Hinge Screw ....   |
| 204297  | ---   | Spool Holder complete, Nos. 200079H, 202068 and 204296 .....                             |
| 202397  | 13399 | Take-up (auxiliary) .....  |
| 200842E | 13399 | " " Screw .....  |
| 202398  | 10247 | " Lever .....  |
| 202399  | 10247 | " " Driving Stud with 202277 .....   |
| 202277  | ---   | Take-up Lever Driving Stud Oil Packing (wick) .....                                      |
| 202400  | 10247 | Take-up Lever Hinge Stud with 202423 .....   |
| 202423  | ---   | Take-up Lever Hinge Stud Oil Packing (wick) .....  |
| 200383C | 10246 | Take-up Lever Hinge Stud Set Screw .....   |
| 202401  | 10247 | Take-up Lever Oiling Felt .....  |
| 200132E | 10247 | " " " " Screw ..   |
| 244048  | 10247 | Tension Disc (back) .....  |
| 244049  | 10247 | " " (front) .....  |
| 202404  | 10247 | " Release Plunger .....  |
| 202405  | 10247 | " " Washer .....   |
| 202407  | 10881 | " Spring .....   |
| 200625F | 10247 | " Stud with 204925 .....   |
| 200061C | 13396 | " " Set Screw .....  |
| 204925  | 13399 | " " Washer .....   |
| 201572B | 10881 | " Thumb Nut .....  |
| 202409  | 10252 | Tension complete, Nos. 200625F, 201572B, 202405, 202407, 202410, 244048 and 244049 ..... |
| 202410  | 10252 | Thread Controller Spring .....   |
| 202411  | 10252 | " " " Stop ....  |
| 200132E | 10247 | " " " " Screw  |
| 202413  | 10252 | " Guide .....  |
| 202414  | 10252 | " " .....  |
| 202415  | 10252 | " " .....  |
| 202417  | 10252 | " " .....  |
| 200582H | 10252 | " " Screw .....  |
| 200355H | 10252 | " " Set Screw .....  |
| 200368H | 13399 | " " " " .....  |
| 202091  | 10252 | " Retainer Sleeve .....  |
| 202092  | 10252 | " " Spring .....   |

## Parts for Machine No. 61w77

| No.     | Plate | Name  |
|---------|-------|---|
| 204058  | 10252 | Thread Retainer Stud .....  |
| 200368H | 13399 | " " " Set Screw ..  |
| 204059  | ---   | Thread Retainer complete, Nos. 202091, 202092 and 204058 .....  |
| 202818  | 13399 | Throat Plate, 50 needle hole, for needle sizes 14 and 15, with 202534, 202619 and two 200583H, for 202282 ..... |
| 202534  | 13399 | Throat Plate Bobbin Case Stop   |
| 202619  | 13392 | " " " " " " Position Pin .....  |
| 200583H | 13399 | Throat Plate Bobbin Case Stop Screw .....   |
| 200577H | 10245 | Throat Plate Screw (2) .....  |

## ACCESSORIES

| No.     | Plate | Name  |
|---------|-------|---|
| 200157B | 13399 | Attachment Screw .....  |
| 202265  | 13392 | Bobbin .....  |
| *225482 | ----- | " Case Screw Driver Blade ...                                   |
| *225483 | ----- | " " " " Handle ...  |
| 225497  | 14334 | Bobbin Case Screw Driver complete, Nos. 225482 and 225483 ...   |
| 12361   | 14334 | Machine Hinge Connection .....                                  |
| 135 x 5 | ----- | Needles, three each, sizes 12 and 14                            |
| 228212  | ----- | Drip Pan (short) with four 1 in. wire nails .....               |
| 41400   | 14334 | Machine Rest Pin (wood) .....                                   |
| 120342  | 14334 | Oiler (copper plated) with 120343                               |
| 120343  | 14334 | " Spout, 3½ in. long .....                                      |
| *225484 | ----- | Screw Driver Blade .....  |
| *225485 | ----- | " " Handle .....  |
| 225498  | 14334 | Screw Driver complete (7½ in. long), Nos. 225484 and 225485 ... |
| 225554  | 14334 | Wrench (steel) .....  |

### BOBBIN WINDER

#### Swing Automatic, Right Hand

|         |       |                                   |
|---------|-------|-----------------------------------|
| 225453  | 10884 | Frame with 202277 and 225438 .... |
| 225454  | 10884 | " Hinge Pin .....                 |
| 202277  | ----- | " Oil Packing (wick) .....        |
| 225438  | 10884 | " " Well Cap .....                |
| 225455  | 10884 | " Spring .....                    |
| 225456  | 10884 | " " Plunger .....                 |
| 202473  | 10885 | Pulley with 200380c .....         |
| 200380c | 13396 | " Set Screw .....                 |
| 225381  | 10884 | Spindle .....                     |
| 225444  | 10884 | Stop Latch .....                  |
| 200056E | 10884 | " " Screw .....                   |
| 225458  | 10884 | " " Thumb Lever .....             |
| 225459  | 10884 | " " " " Hinge Stud                |
| 225459  | 10884 | " " " " Joint Stud                |
| 202478  | 10884 | " " Trip Lever .....              |
| 200299H | 10884 | " " " " Hinge Screw               |
| 225461  | 10881 | Tension Bracket with 201499B .... |
| 200082D | 10881 | " " Screw .....                   |
| 228026  | 10884 | " " " Washer .....                |
| 2102    | 10881 | " Disc .....                      |

### Accessories

| No.      | Plate | Name   |
|----------|-------|--|
| 202407   | 10881 | Tension Spring .....   |
| 201499B  | 10881 | " Stud .....   |
| 201572.3 | 10881 | " " Thumb Nut .....  |
| 225462   | 10881 | Bobbin Winder Tension Bracket complete, Nos. 201572B, 202407, 225461 and two 2102 .....  |
| 225433   | 10885 | Bobbin Winder and Tension Bracket Base .....   |
| 225382   | 10885 | Universal Bobbin Winder complete, Nos. 200056E, 200082D, 200299H, 202473, 202478, 225381, 225433, 225444, 225453 to 225456, 225458, 225462, 228026, two each 225459 and wood screws ¾ in., No. 12, R.H.B. .... |

### KNEE LIFTER

|        |       |   |
|--------|-------|---|
| 2763   | 13395 | Rock Shaft .....  |
| 228278 | 13395 | " " Hanger (back) with 356c .....   |
| 228279 | ----- | Rock Shaft Hanger 228278 with 202452 and 228282 .....   |
| 228280 | 13395 | Rock Shaft Hanger (front) with two 356c .....   |
| 228281 | ----- | Rock Shaft Hanger 228280 with 202452 and 228282 .....   |
| 228282 | 13395 | Rock Shaft Hanger Bracket with two wood screws ¾ in., No. 12 ...                                    |
| 202452 | 13399 | Rock Shaft Hanger Hinge Pin ....  |
| 202455 | 13395 | " " Knee Arm .....  |
| 356c   | 13399 | " " " " Set Screw ..  |
| 228284 | 13395 | " " " Plate with 356c ..  |
| 356c   | 13399 | " " " " Set Screw ..  |
| 228283 | 13395 | " " Lifting Lever with two 356c .....   |
| 227728 | 13395 | Rock Shaft Lifting Lever Rod with 227729 .....  |
| 227729 | ----- | Rock Shaft Lifting Lever Rod Cap  |
| 356c   | 13399 | " " " " " Set Screw .....   |
| 356c   | 13399 | Rock Shaft Lifting Lever Set Screw  |
| 356c   | 13399 | " " Set Screw .....   |
| 228285 | 13395 | Knee Lifter Rock Shaft complete, Nos. 2763, 202455, 227728, 228279, 228281, 228283 and 228284 ..... |



Accessories

THREAD UNWINDER

| No.     | Plate | Name   |
|---------|-------|--|
| 225323  | 14083 | Spool Rest (for one spool) with 201018c .....  |
| 225325  | 14083 | Spool Rest (for two spools) with 201018c .....   |
| 225388  | 14083 | Spool Rest Rod .....   |
| 200383c | 10246 | " " " Set Screw .....  |
| 201018c | 13392 | " " " Set Screw .....  |
| 202490  | 14083 | " Stand with 200383c .....   |
| 225391  | 14083 | Thread Guide .....   |
| 201696r | 13399 | " " Lock Nut .....   |
| 225326  | 13399 | " " Position Cup .....   |
| 225324  | 14083 | " " Rod with 208E and 225322 .....   |
| 208E    | 13399 | Thread Guide Rod Screw .....   |
| 225322  | 13399 | " " " Washer .....   |
| 225397  | 14083 | Thread Unwinder (for three spools) complete, Nos. 201696r, 202490, 225323 to 225326, 225388, three each 225391 and wood screws 3/4 in., No. 12 ..... |

MISCELLANEOUS PARTS

Used in conjunction with Thread Unwinder

|        |       |                                |
|--------|-------|--------------------------------|
| 27739  | 13398 | Thread Cone (wood) .....       |
| 60913  | 14083 | Spool Weight with 60914 .....  |
| 60914  | —     | " " Center Pin .....           |
| 225377 | 14083 | " Wire, for small spools ..... |

PLATE 10244—FULL SIZE

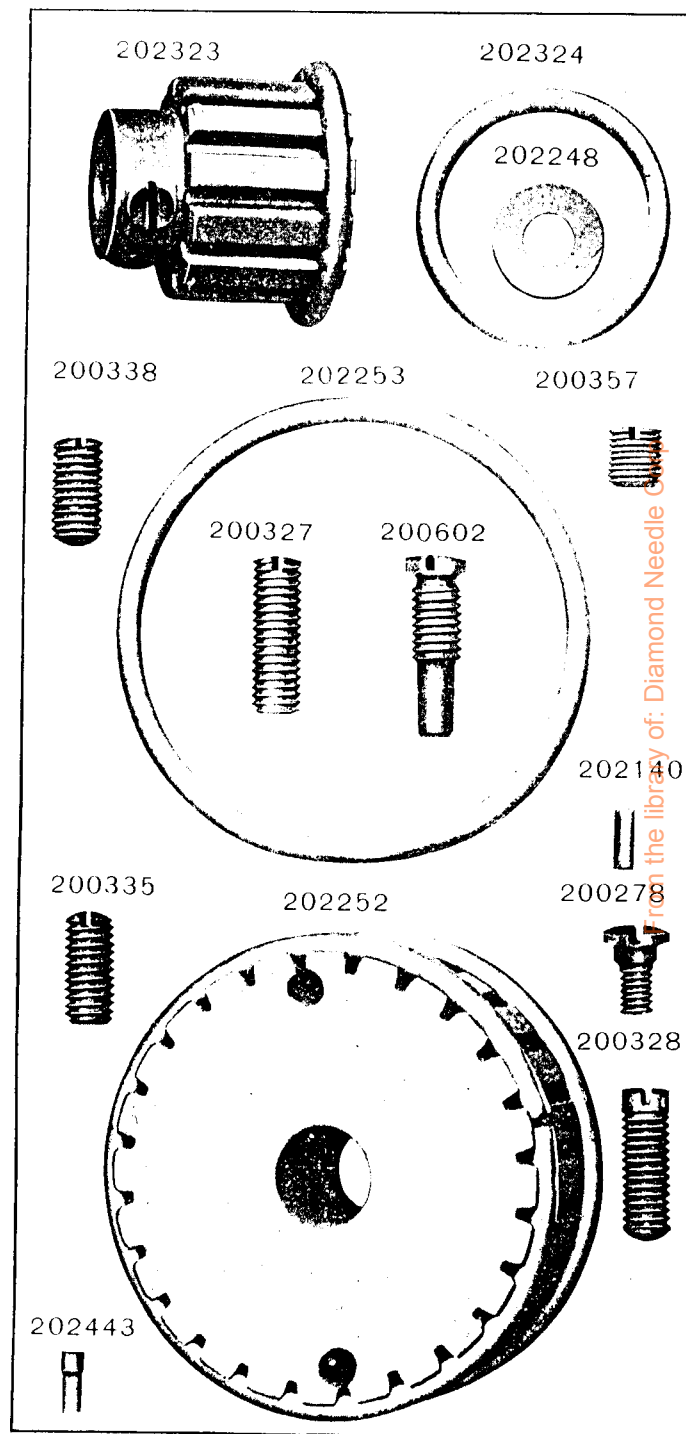

PLATE 10245—FULL SIZE

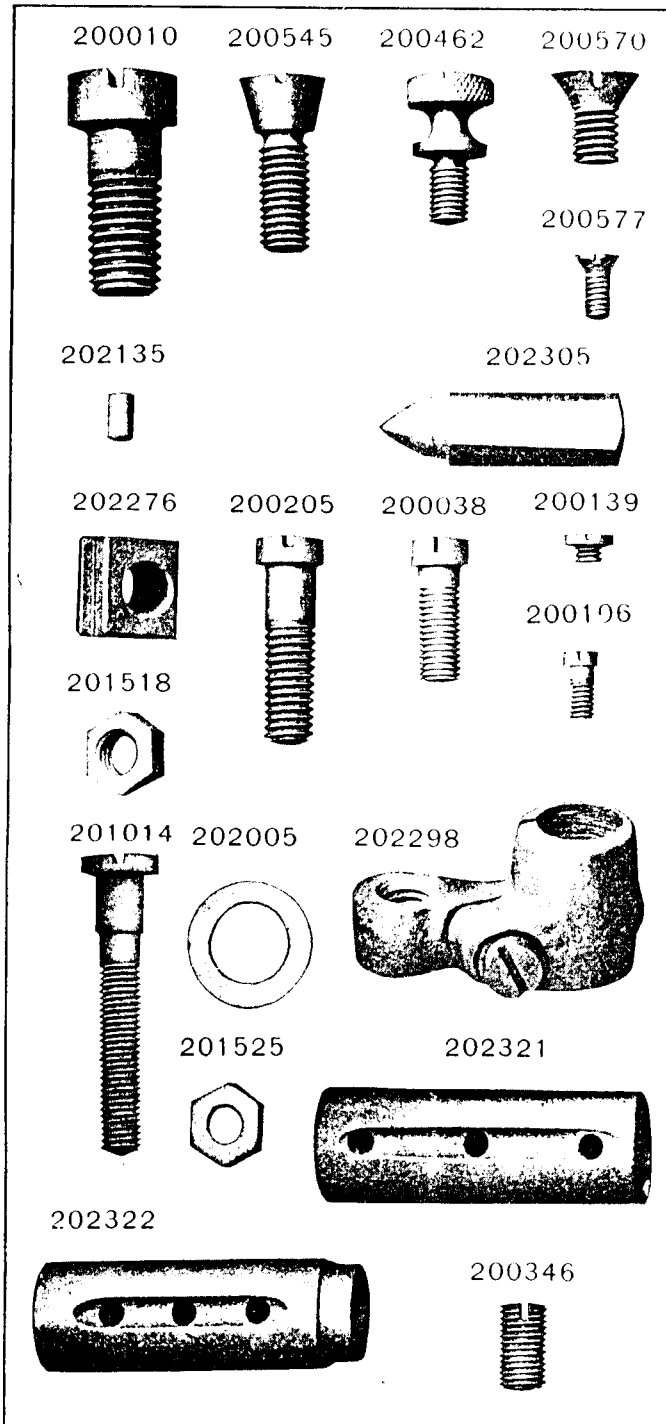
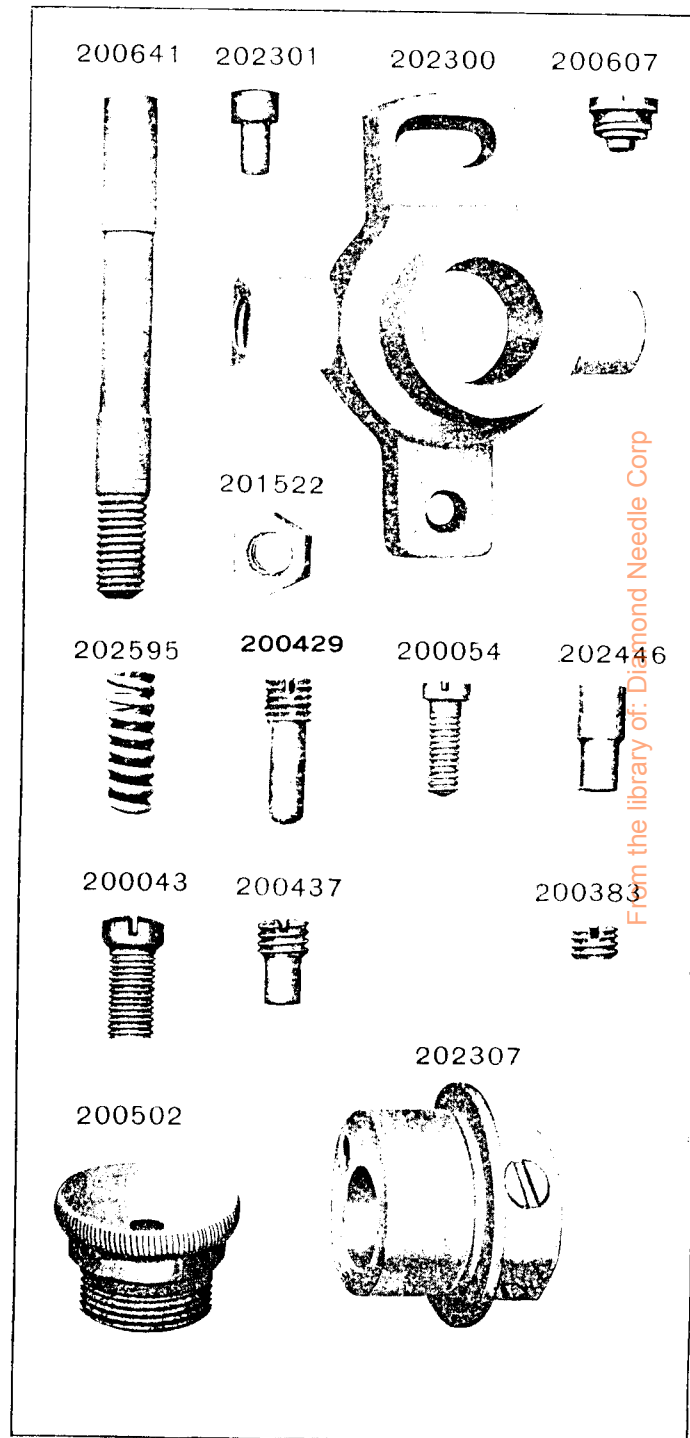

PLATE 10246—FULL SIZE



From the library of: Diamond Needle Corp

PLATE 10247—FULL SIZE

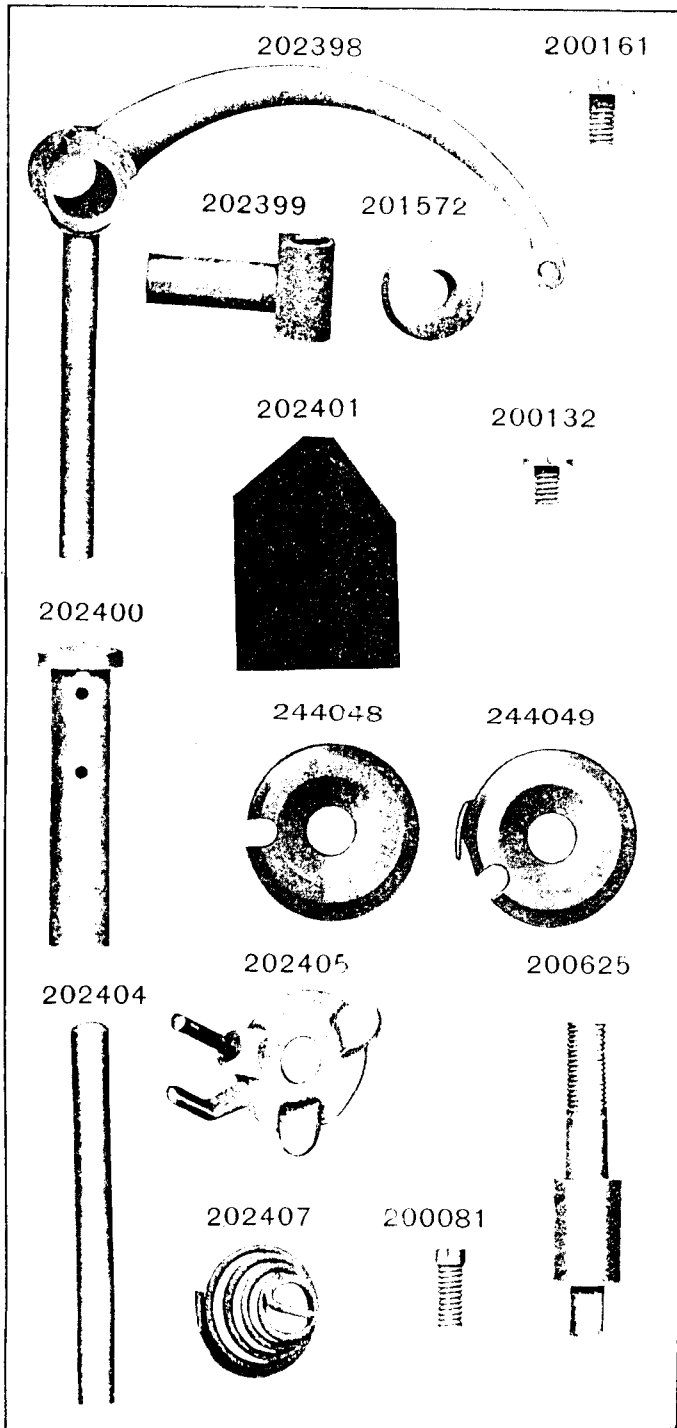
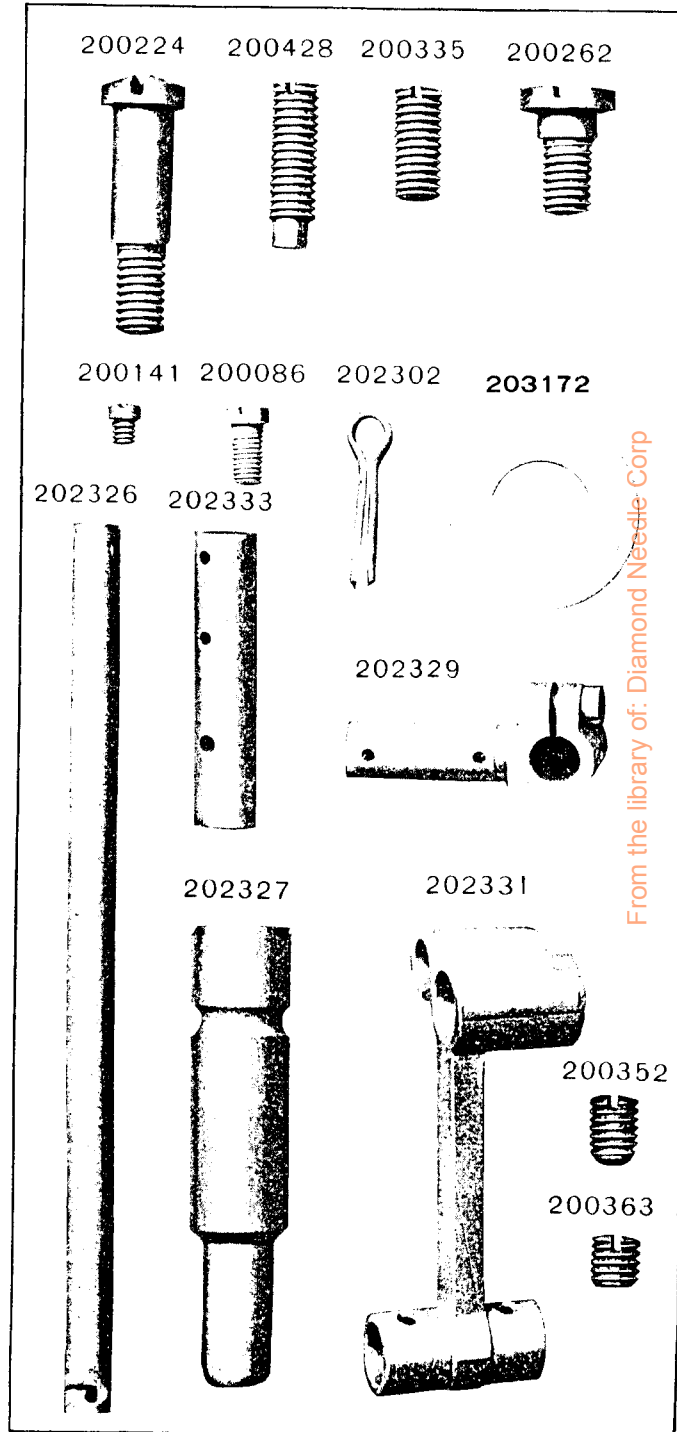

PLATE 10248—FULL SIZE



From the library of: Diamond Needle Corp

PLATE 10249—FULL SIZE

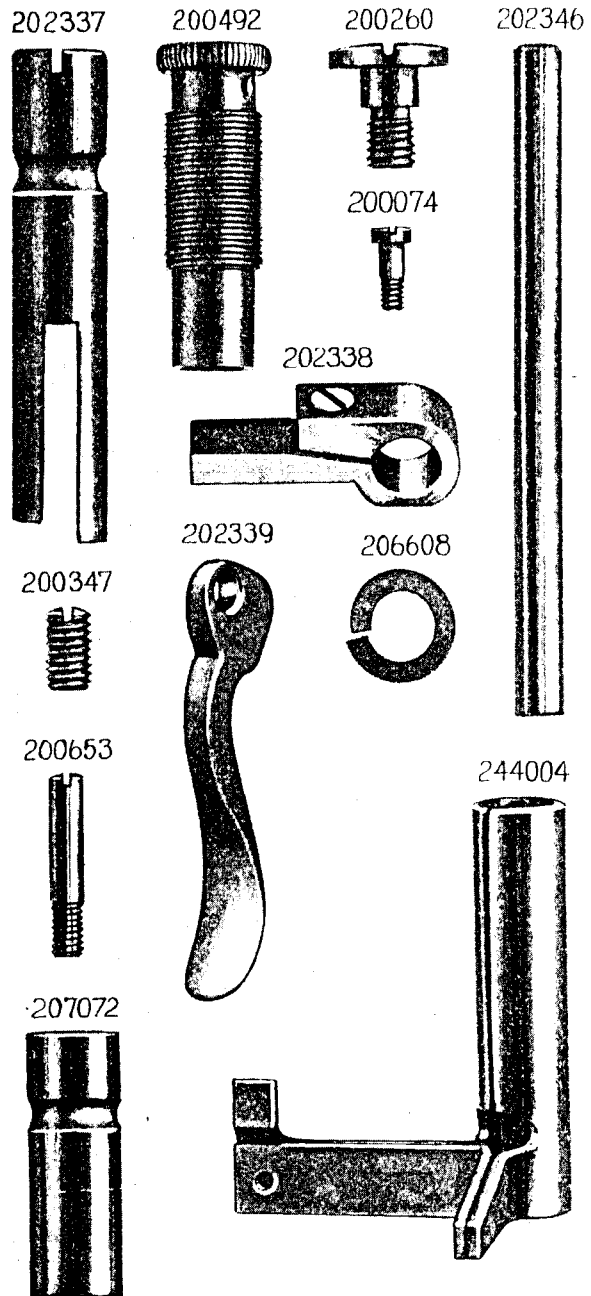

PLATE 10252—FULL SIZE

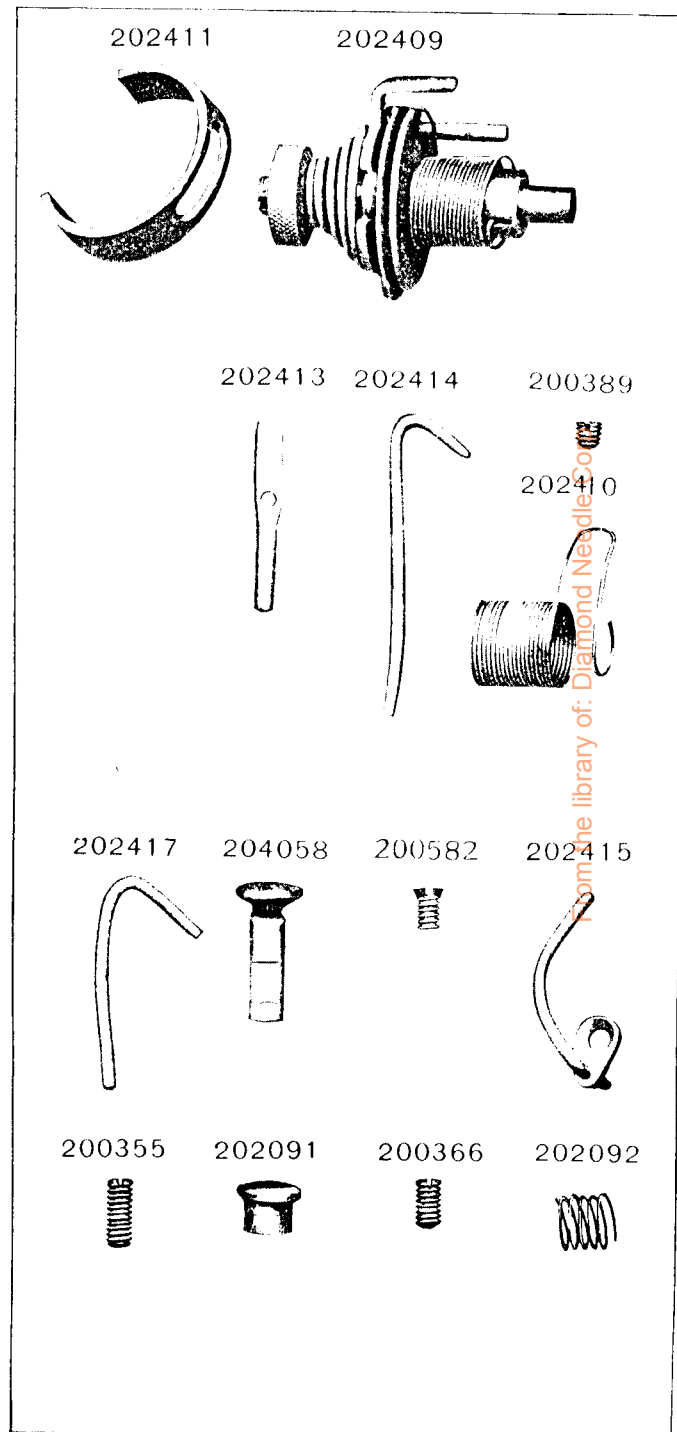
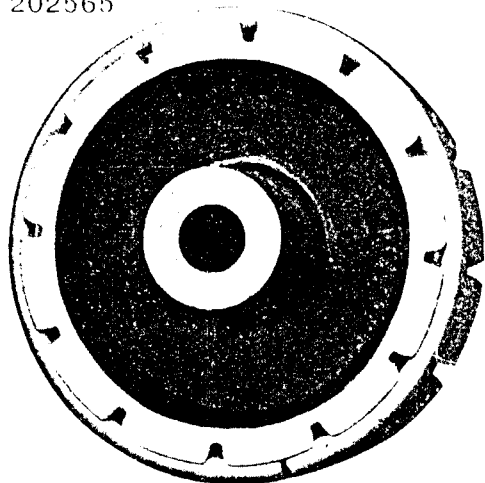
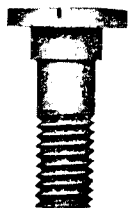

PLATE 10285—FULL SIZE

202565



200231



200057



201516



201522



200055



200558



200759



200769



225532



202562

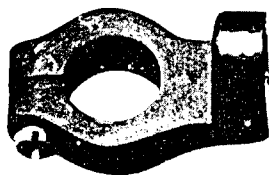
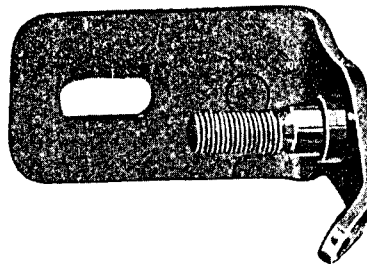

PLATE 10881—FULL SIZE

225461



200082



202104



2102

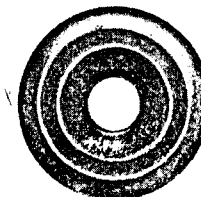

225462

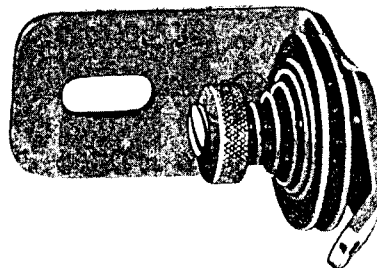

202407



201499



201572



From the library of: Diamond Needle Corp

PLATE 10884—FULL SIZE

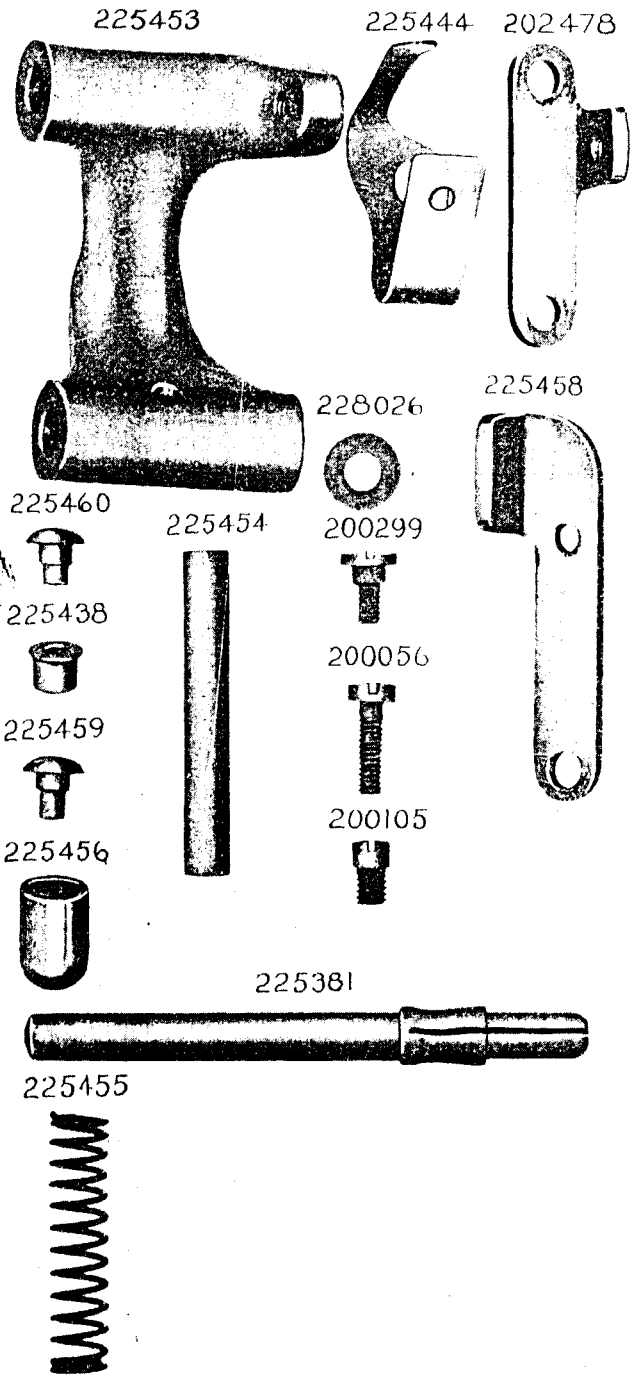
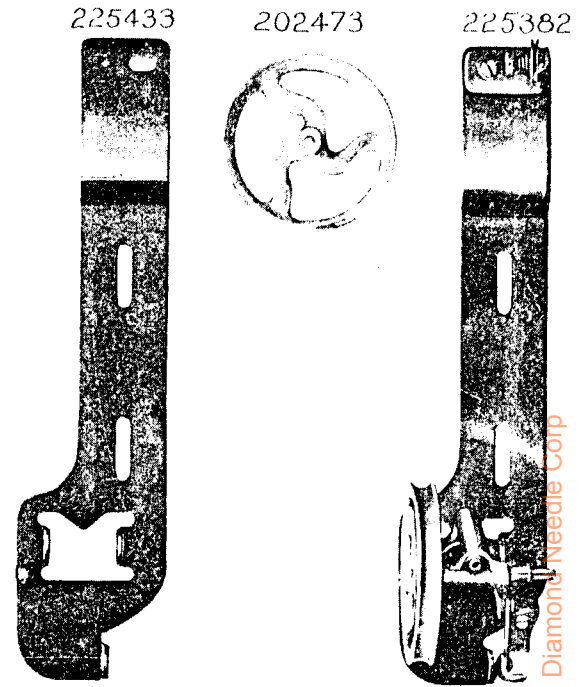

PLATE 10885—ONE-FOURTH SIZE



From the library of: Diamond Needle Corp

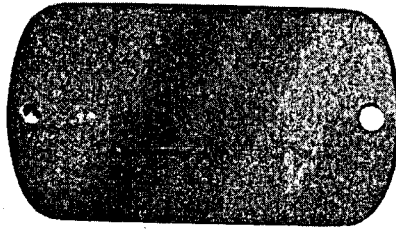

PLATE 13372—ONE-HALF SIZE

202567



202247



202563



202530



203159

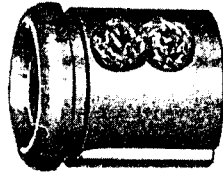

207080

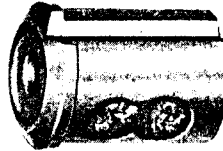

202566



PLATE 13374—ONE-FOURTH SIZE

202303



202306



202297



202961



202962

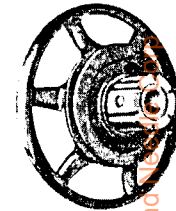

206542

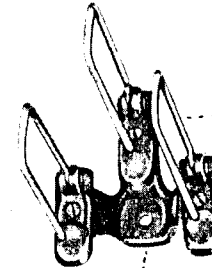

202308



204296

202068

206541

From the library of: Diamond

PLATE 13392—FULL SIZE

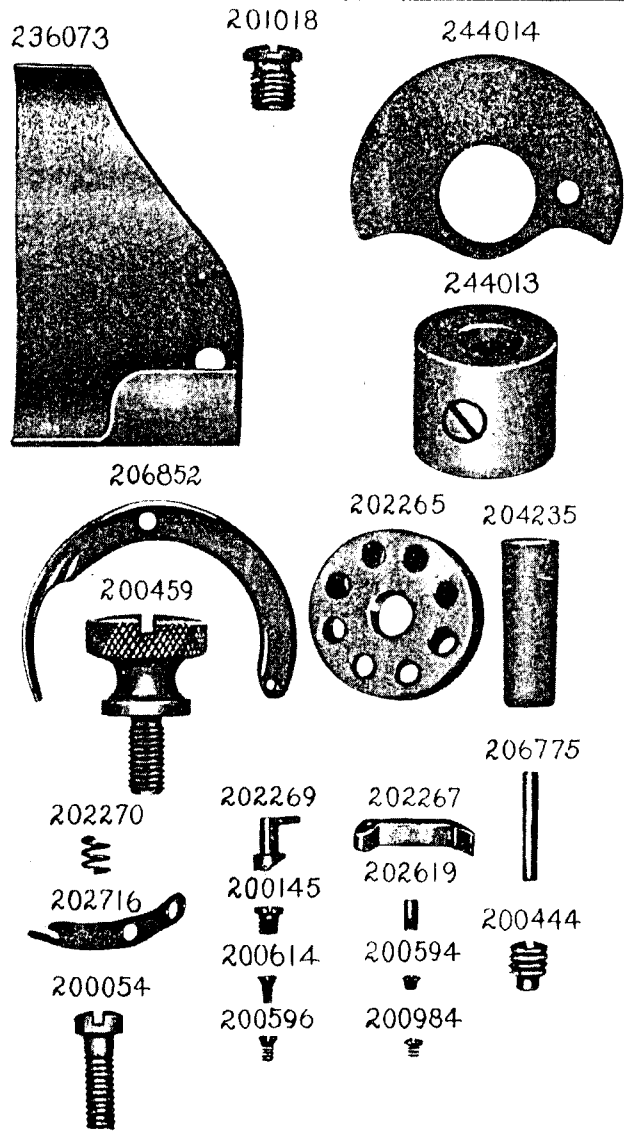
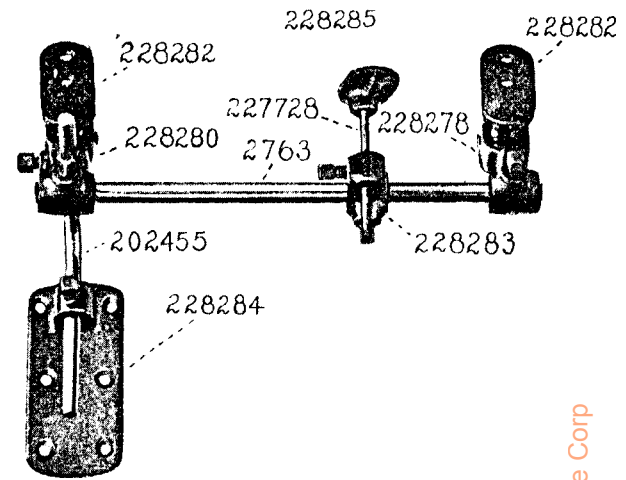

PLATE 13395—ONE-FOURTH SIZE



From the library of: Diamond Needle Corp



PLATE 13396—FULL SIZE

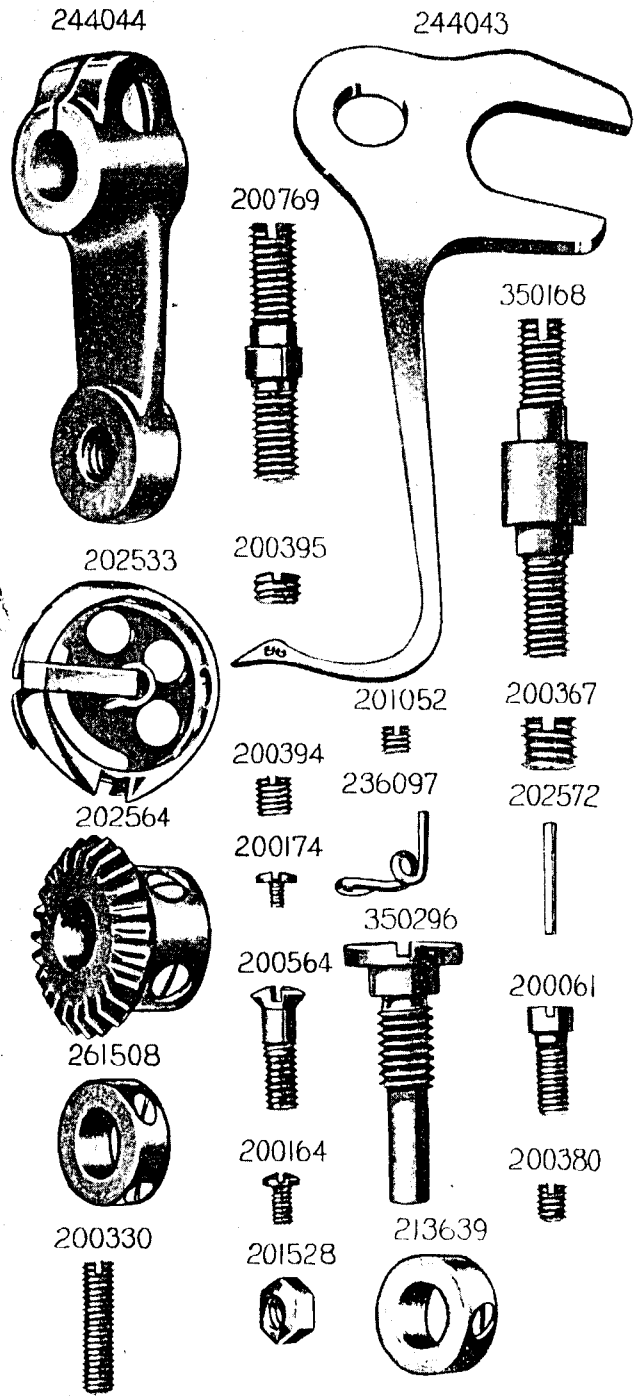
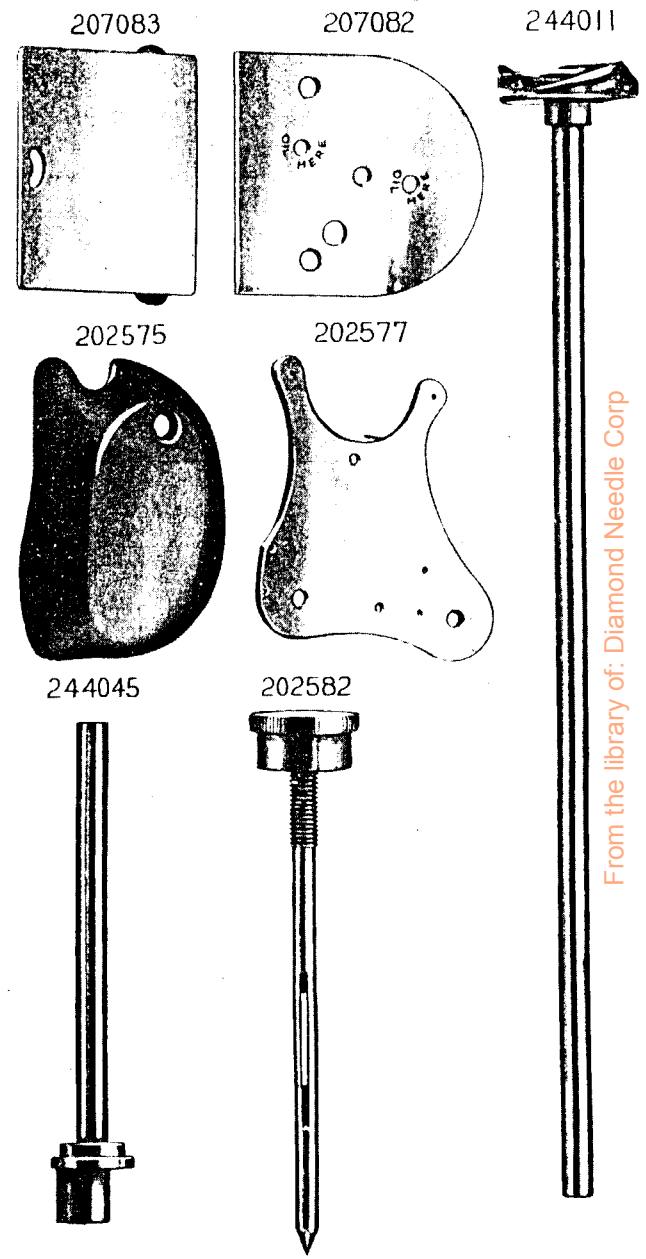

PLATE 13397—ONE-HALF SIZE



From the library of: Diamond Needle Corp

PLATE 13398—ONE-HALF SIZE

244034 237837 202447 202335

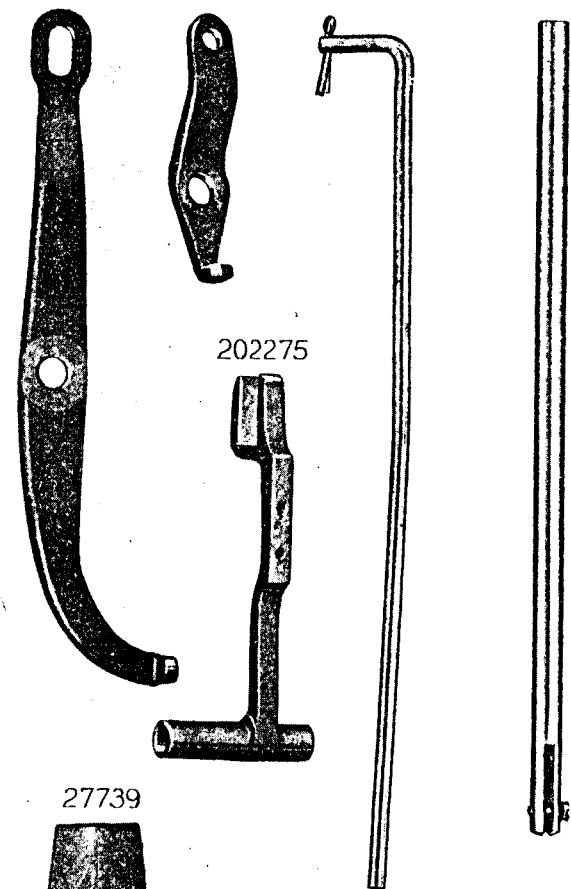

202275

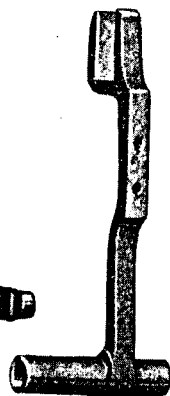

27739



202328

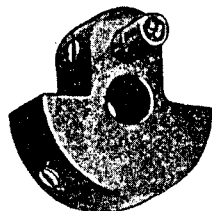
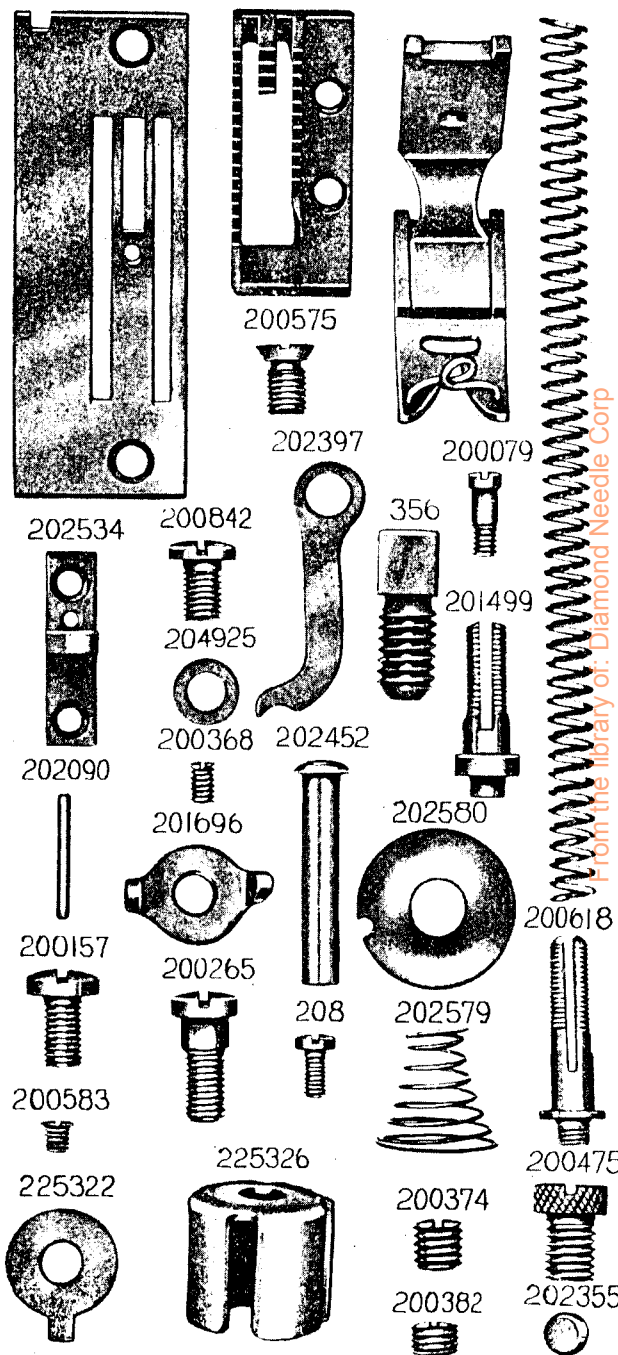

PLATE 13399—FULL SIZE

202818 202282 244047 202343



200575

202397

200079

202534

200842

356

204925

201499

202090

200368

202452

201696

202580

200618

200157

200265

208

202579

200583

225326

200374

200475

225322

200382

202355

From the library of: Diamond Needle Corp

PLATE 14083—ONE-SIXTH SIZE

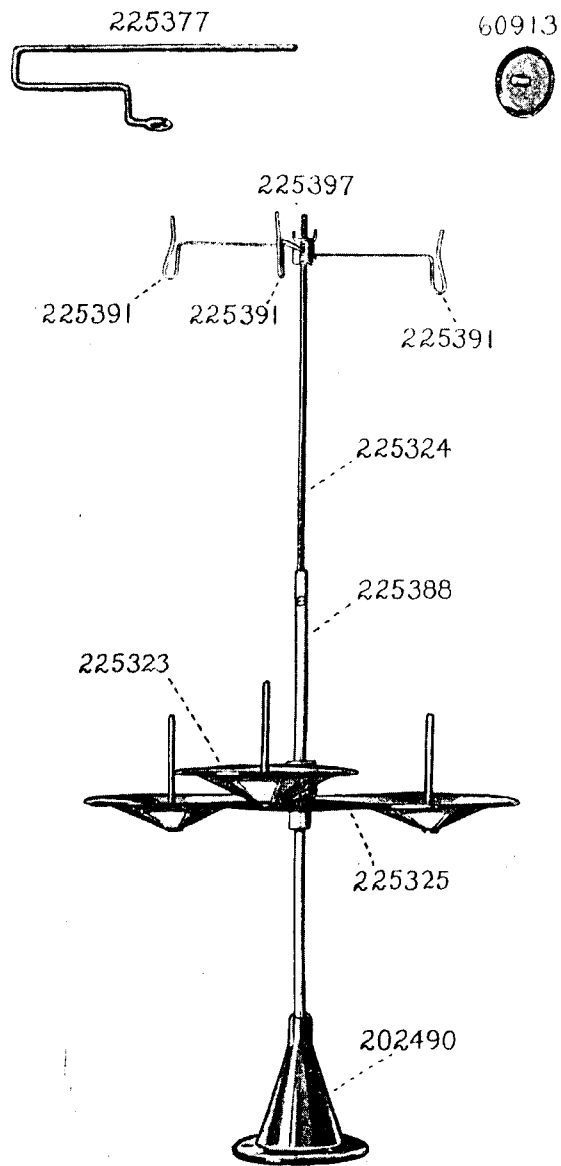

PLATE 14334—ONE-HALF SIZE

